

# Outdoor Cabinet System Solution

## 1. Configuration List

No.	ITEM	Module Type	QTT	Remark
1	Equipment Cabinet	ODC-E18AC06A	1	(1) Cabinet inner dimension is 780(W)*846(D)*1720(H) (2) Including 600W AC air-conditioner,base,rack,lighting,door lock etc.
2	Power-supply Cabinet	ODC-P18AC15A	1	(3) Cabinet inner dimension is 780(W)*846(D)*1720(H) (4) Including 1500W AC air-conditioner,base,rack,lighting,door lock etc.
3	Battery Cabinet	ODC-B18AC03A	1	(5) Cabinet inner dimension is 780(W)*846(D)*1720(H) (6) Including 300W AC air-conditioner,base,rack,lighting,door lock etc.

## 2. Configuration Layout

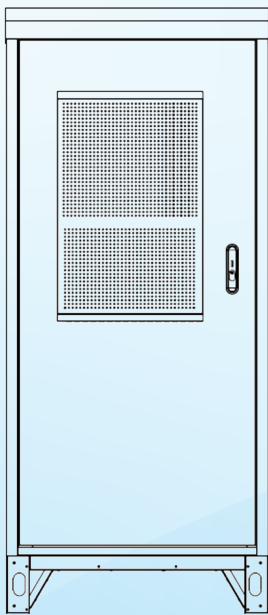

Equipment Cabinet

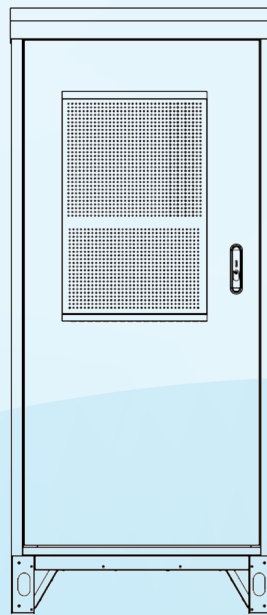

Power-supply Cabinet  
Single Cabinet Solution

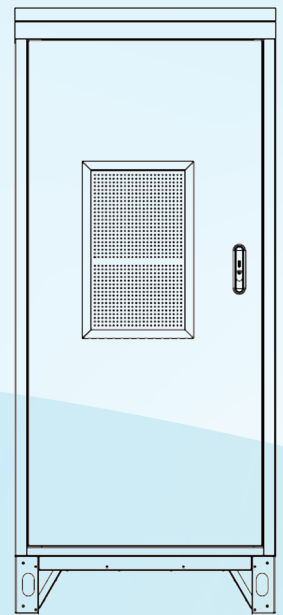

Battery Cabinet

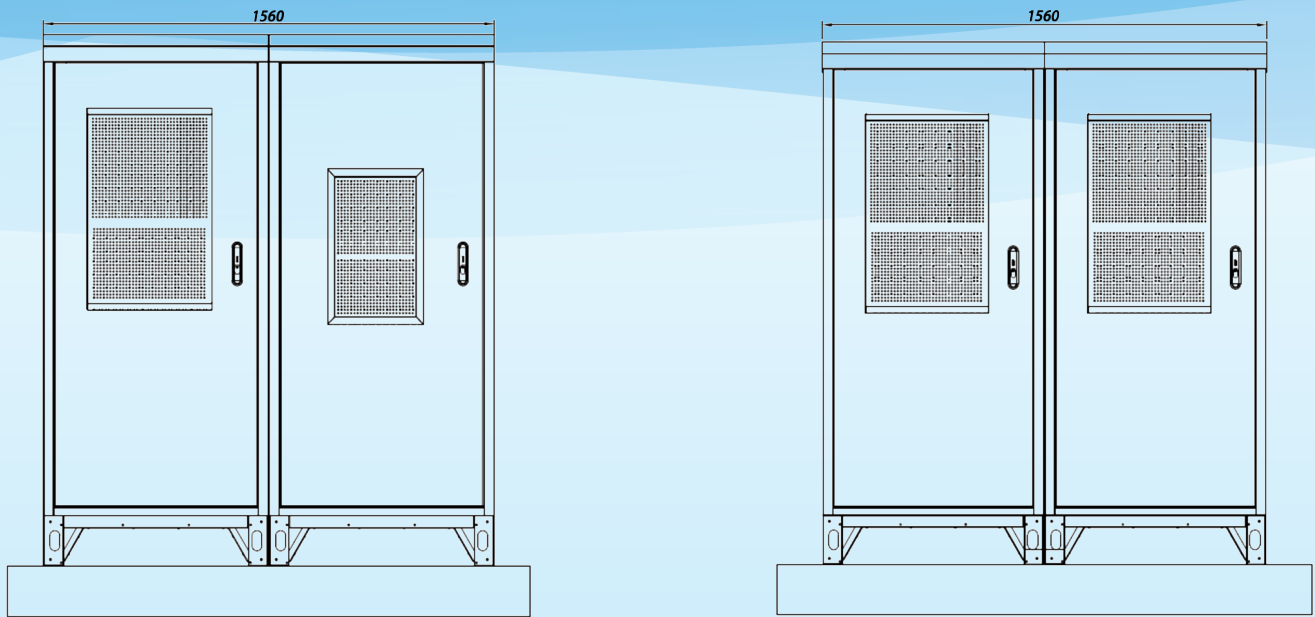

Double Cabinet Solution

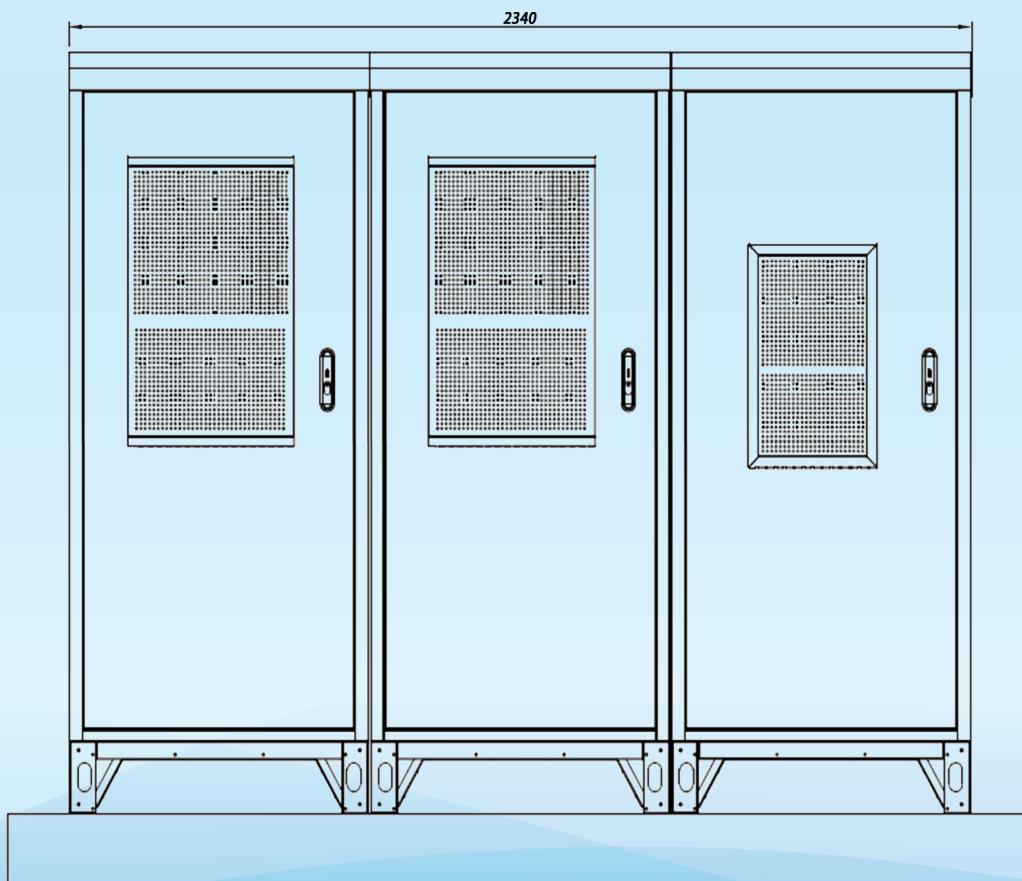

Triple Cabinet Solution

### 3. Cabinet Production

Cabinet Basic Information :

No.	ITEM	Parameter
1	Inner Dimension	780mm ( W ) *846mm ( D ) *1720mm ( H )

2	Base Area	780mm ( W ) *846mm ( D )
3	Base Height	150mm
4	User Space	37U
5	Wall Panel Material	Sandwich Panel : Pre-painted Galvanized Steel+EPS
6	Wall Panel Thickness	45mm
7	Protection Level	IP55
8	Shipping Mode	Whole Assembly
9	Weight	120kg ( Including Carton Box )
10	Weight	135kg ( Including Wooden Box )

## Equipment Cabinet

✧ Module Type : ODC-E18AC15A

✧ Cabinet Dimension

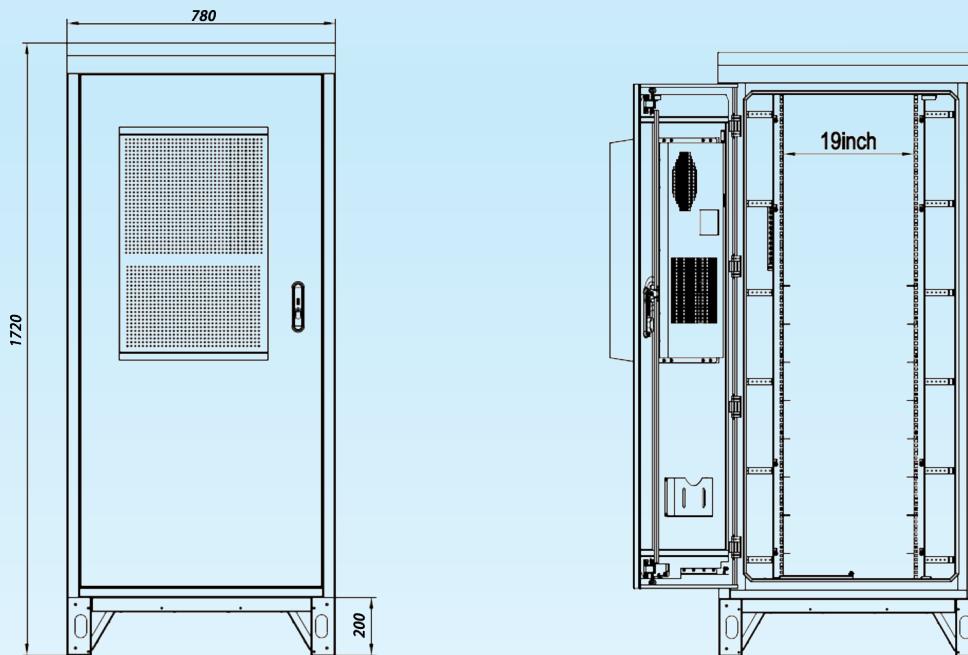

✧ Configuration List

No.	ITEM	Specification	QTT	Unit	Remark
1	Cabinet Body	780*846*1720mm	1	PCS	
2	Temp. Control Mode	AC 600W Air-conditioner	1	PCS	
3	Lock	Three-point door lock	1	PCS	
4	Rack	37U , 19inch	1	PCS	
5	L-shape Rail		5	Pair	
6	Grounding Bar	10 pcs M6 grounding bolt	1	PCS	
7	Cable Inlet	Φ50	8	PCS	

8	Fixation Parts	Panel Bolt and Nut	20	SET	
9	Sealing Clay		1	PCS	
10	Expansion Bolt	M10*70	4	PCS	
11	Lighting	-48V , LED Lamp	1	PCS	
12	Package	Carton Box	1	PCS	
12	Package	Wooden Box	1	PCS	

**Power-supply Cabinet (Upper and lower is ventilated)**

- ✧ Module Type : ODC-P18AC15A
- ✧ Cabinet Dimension

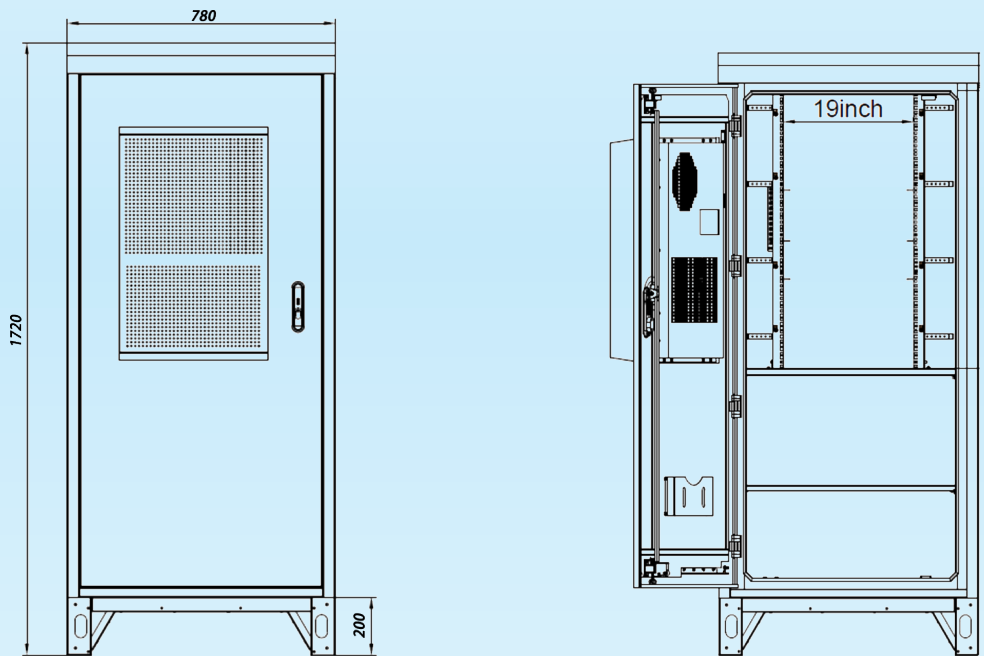

✧ Configuration List

No.	ITEM	Specification	QTT	Unit	Remark
1	Cabinet Body	780*846*1720mm	1	PCS	
2	Temp. Control Mode	AC 600W Air-conditioner	1	PCS	
3	Lock	Three-point door lock	1	PCS	
4	Rack	22U19inch+2-layer battery rack	1	PCS	
5	L-shape Rail		3	Pair	
6	Grounding Bar	10 pcs M6 grounding bolt	1	PCS	
7	Cable Inlet	Φ50	8	PCS	
8	Fixation Parts	Panel Bolt and Nut	20	SET	
9	Sealing Clay		1	PCS	
10	Expansion Bolt	M10*70	4	PCS	

11	Lighting	-48V , LED Lamp	1	PCS	
12	Package	Carton Box	1	PCS	
12	Package	Wooden Box	1	PCS	

### Power-supply Cabinet (Upper and lower is not ventilated)

- ✧ Module Type : ODC-P18MX01A
- ✧ Cabinet Dimension

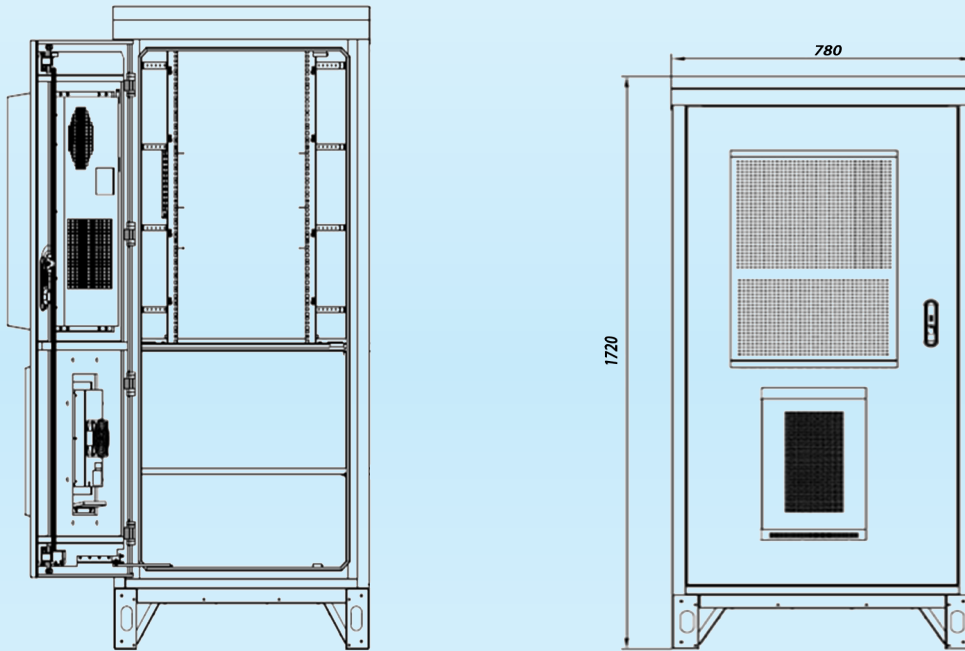

### ✧ Configuration List

No.	ITEM	Specification	QTT	Unit	Remark
1	Cabinet Body	780*846*1720mm	1	PCS	
2	Temp. Control Mode	80W/K Heater-exchanger	1	PCS	Equipment Cabin
3	Temp. Control Mode	200W TEC air-conditioner	1	PCS	Battery Cabin
4	Lock	Three-point door lock	1	PCS	
5	Rack	22U19inch+2-layer battery rack	1	PCS	
5	L-shape Rail		3	Pair	
6	Grounding Bar	10 pcs M6 grounding bolt	1	PCS	
7	Cable Inlet	Φ50	8	PCS	
8	Fixation Parts	Panel Bolt and Nut	1	SET	
9	Sealing Clay		4	PCS	
10	Expansion Bolt	M10*70	1	PCS	
11	Lighting	-48V , LED Lamp	1	PCS	

12	Package	Carton Box	1	PCS	
12	Package	Wooden Box	1	PCS	

## Battery Cabinet

- ✧ Module Type : ODC-B18AC03A
- ✧ Cabinet Dimension

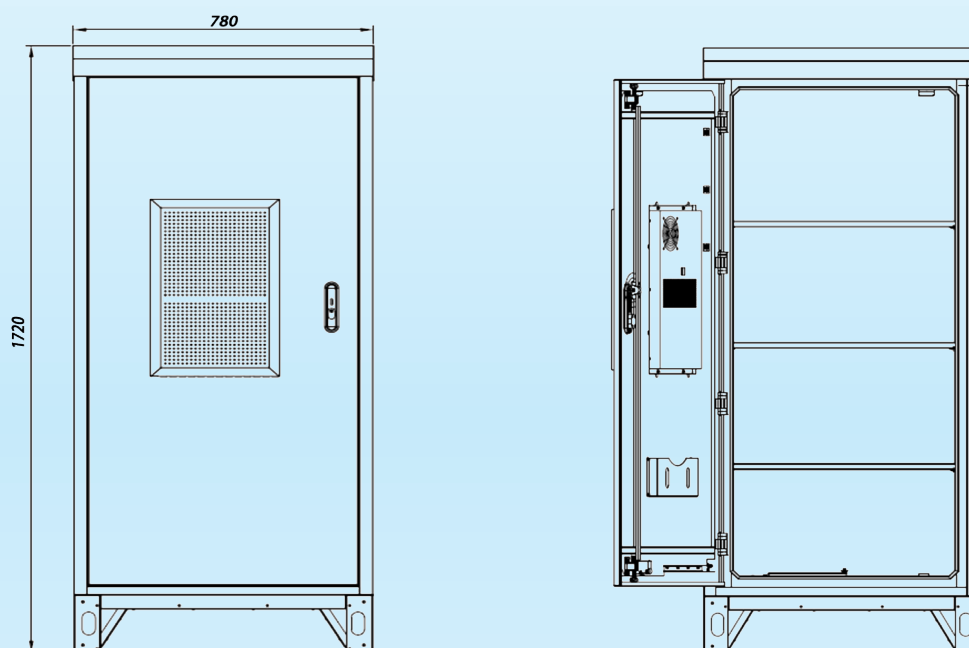

### ✧ Configuration List

No.	ITEM	Specification	QTT	Unit	Remark
1	Cabinet Body	780*846*1720mm	1	PCS	
2	Temp. Control Mode	AC 600W Air-conditioner	1	PCS	
3	Lock	Three-point door lock	1	PCS	
4	Rack	4-layer battery rack	1	PCS	
5	Cable Inlet	Φ50	8	PCS	
6	Sealing Clay		4	PCS	
7	Expansion Bolt	M10*70	1	PCS	
8	Lighting	-48V , LED Lamp	1	PCS	
9	Package	Carton Box	1	PCS	
9	Package	Wooden Box	1	PCS	