

Floor Type Cabinet

Feature:

- ◆ Exquisite design with precise craftsmanship;
- ◆ Welded steel frame for front and back part, can be flat packing, easy to transfer;
- ◆ Arc shaped vented front door with hexagonal holes, can turn over 180 turning degree;
Vented rear door with hexagonal holes;
- ◆ Removable side panel with latch, easy to install, optional lock;
- ◆ Adjustable feet and castors are available simultaneously;
- ◆ Cable entry on the top, adjustable cable entrance at the bottom with panel;
Advanced handle locks for front door, optional other lock;
- ◆ S-shaped mounting profile, free to move forward and back;
- ◆ Efficient buying kit of cabinet on floor; earthing kit;
- ◆ Optional plinth to fix cabinet on floor; under base cable entry;
- ◆ Various optional Accessories for common using;
- ◆ Unassembled packing, about 2/5 of original volume, save container space;

Standard:

Comply with ANS/EIA RS-310-D, IEC297-2,
DIN41491, PART7, DIN41491, PART7, ETSI Standard;

Material:

- ◆ SPCC quality cold rolled steel
- ◆ Thickness: Mounting profile: 2.0mm;
- ◆ mounting angle: 1.5mm; other 1.2mm;
- ◆ Loading Capacity;
- ◆ static loading: 800kg (on the adjustable feet)
- ◆ Degree of protection: IP20
- ◆ Surface finish:
- ◆ Degreasing, pickling, Phosphating, Powder Coated;



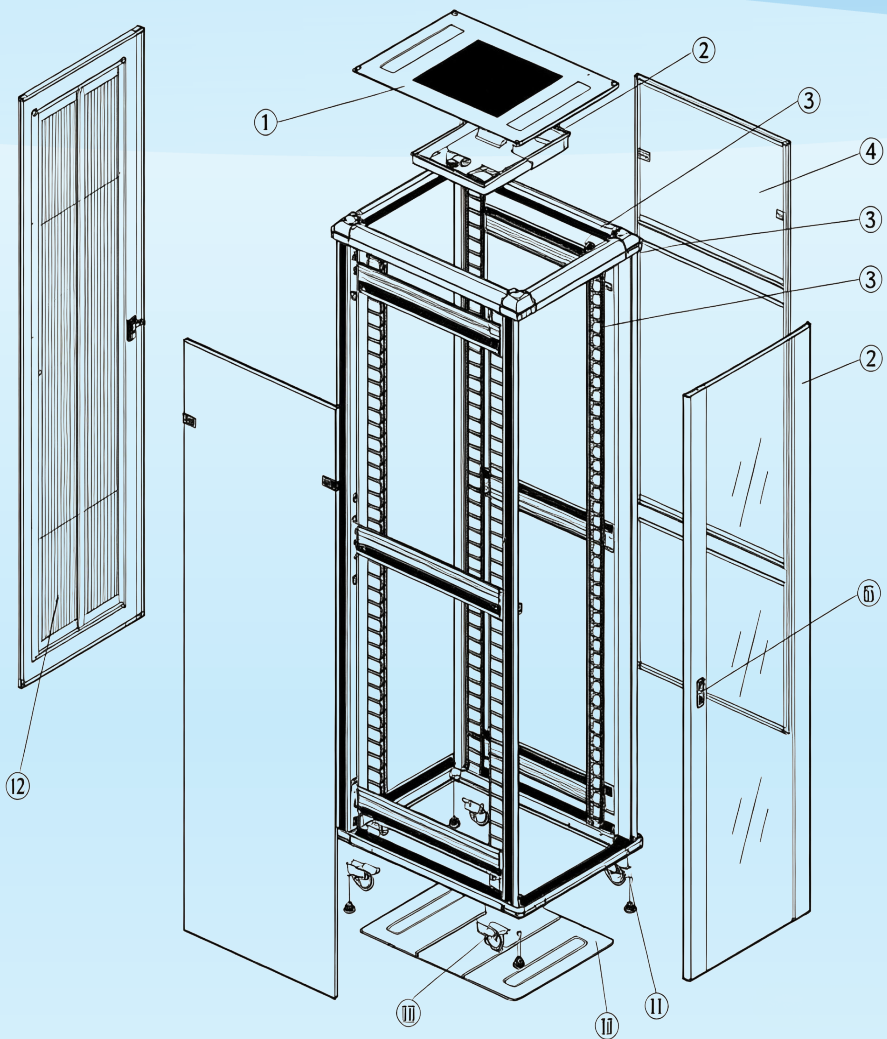

- ① Top cover
- ② Fan unit {Option}
- ③ Mounting angle
- ④ Side panel {option lock}
- ⑤ Aluminum alloy frame
- ⑥ Mounting profile
- ⑦ Tempered glass {front door}
- ⑧ Advanced moon-shaped lock
- ⑨ Bottom panel
- ⑩ Adjustable feet
- ⑪ 2*castor
- ⑫ Perforated door {rear door}

